

NOTES:

1. RECOMMENDED CHARGING VOLTAGE: 14.6 ± .2 Volts.
2. TERMINAL INSTALLATION TORQUE: 50 IN-LB. MAX
3. CAPACITY: 25 AMPERE-HOURS
4. WEIGHT: 24.9 POUNDS
5. OPERATING POSITION: ANY
MOUNTING POSITION: ANY
6. TECHNOLOGY: RG (RECOMBINANT GAS), SEALED LEAD-ACID, IMMOBILIZED ELECTROLYTE. CONTAINS NO FREE LIQUID.
7. TEMPERATURE - OPERATING: -40°F TO 176°F (-40C TO +80C).
STORAGE: -85°F TO 176°F (-65C TO +80C).
8. ALTITUDE: -1000 TO 30,000 FEET
9. COLD CRANKING: 300 AMPS MINIMUM FOR 30 SECONDS AT NOT LESS THAN 8.0 VOLTS AT -20 DEG C.
10. TERMINALS: M6X1.0, HEX-HEAD, STAINLESS STEEL BOLT, 12 MM LONG.
11. WARNING - CONTAINS HAZARDOUS MATERIALS (LEAD AND SULFURIC ACID). CASE IS SEALED AND SHOULD NOT BE OPENED. FAULT CURRENTS OF UP TO 1200 AMPS MAY BE EXPECTED IF BATTERY IS INADVERTENTLY SHORTED. ALL BATTERY HANDLING SAFETY PRACTICES SHOULD BE OBSERVED.
12. APPROVED DISPOSAL: HANDLE PER LOCAL REGULATIONS LIKE ANY OTHER LEAD-ACID, VEHICULAR BATTERY.
13. CAUTION - OBSERVE POLARITY WHEN INSTALLING. REVERSAL OF LEADS WILL DAMAGE OTHER DEVICES IN THE AIRCRAFT.
14. CHARGING CURRENT LIMIT: NONE

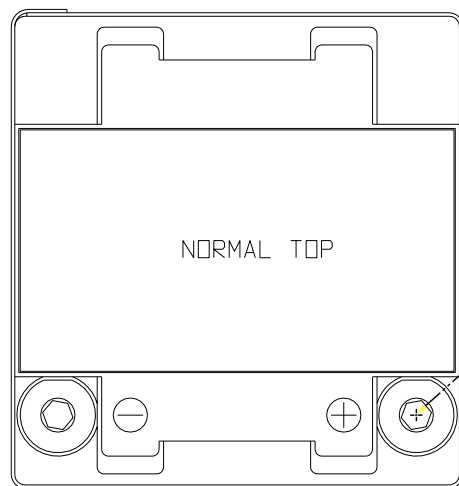

M6 x 1.0 Thd'd Hole
0.40 inch deep (2 pl)

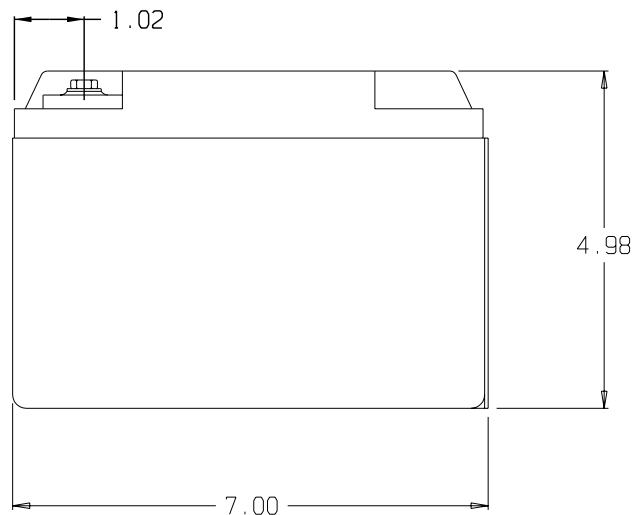
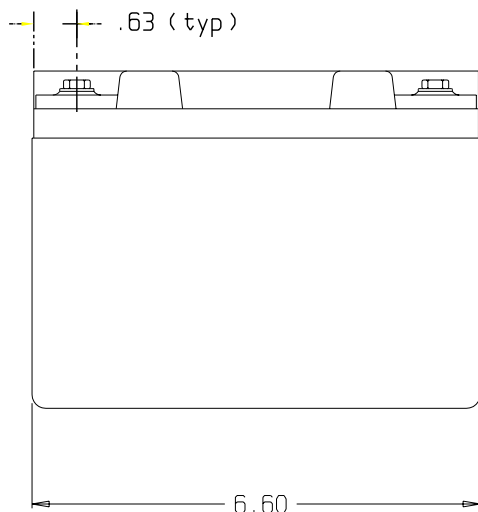

① BATTERY, 12V, 25 AH

B & C Specialty Products P.O. Box B, Newton, Kansas 67114		
TITLE ENVELOPE DRAWING BATTERY, 12V, 25 A.H. SLA, JACKETED		
DRAWING NO.	BC100-MJ	REVISION
SCALE	JOB NO.	DATE 1/3/00
		SHEET 1 OF 1