

EXPLANATION OF TERMINALS 1 THRU 6

1. H/L Voltage Sense
2. Warning Light
3. D.V. Press to Test
4. Field
5. Ground
6. Field Supply

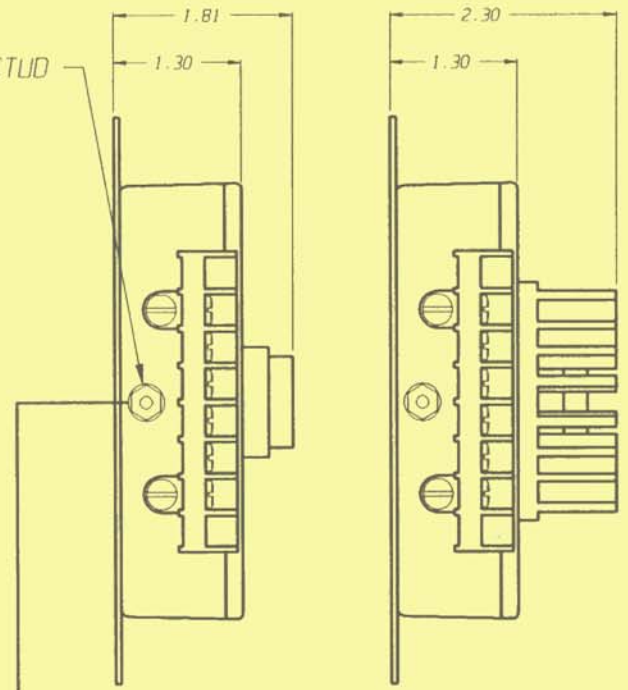
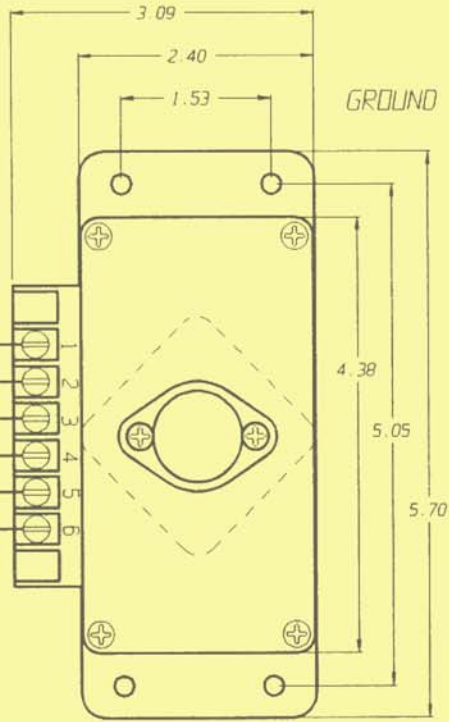
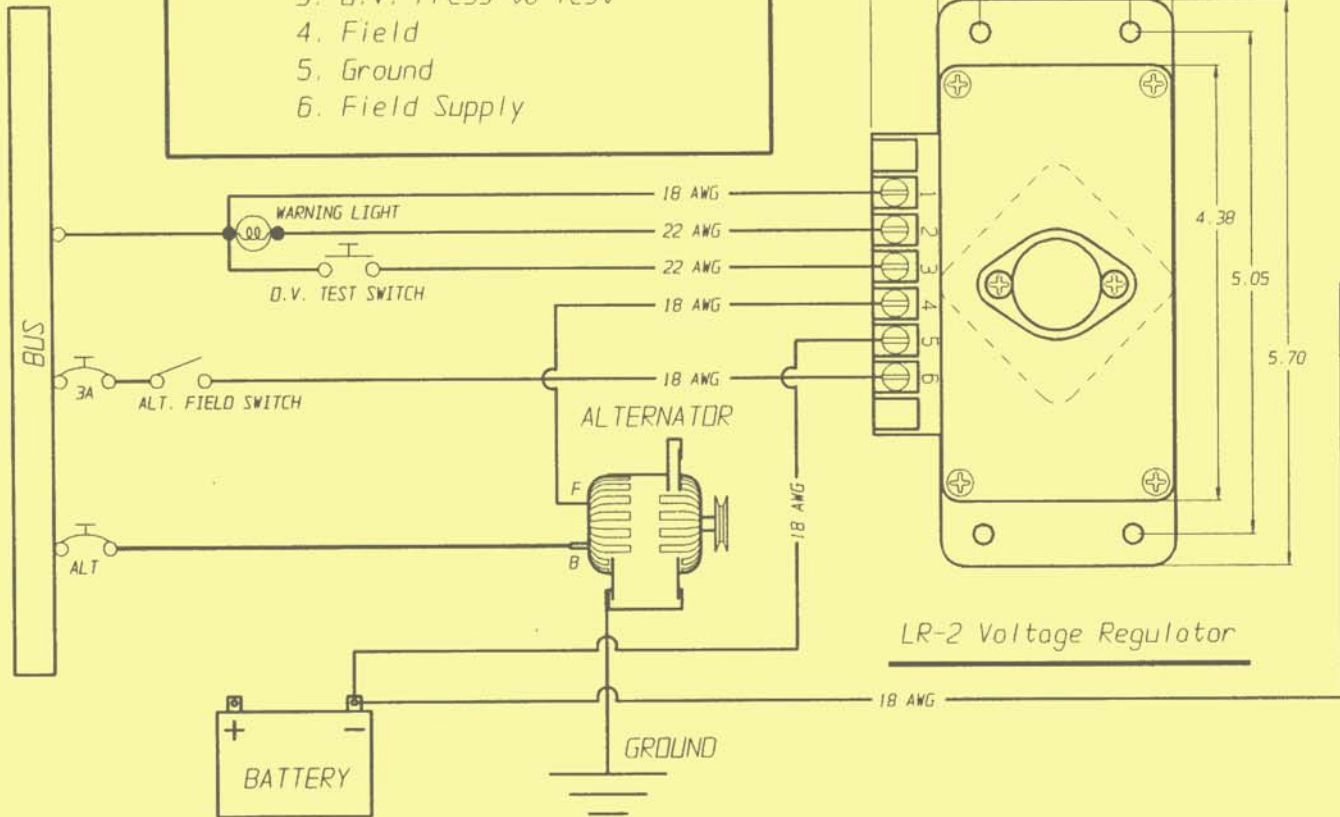

12 Volt LR-2

24 Volt LR-2

LR-2 Voltage Regulator

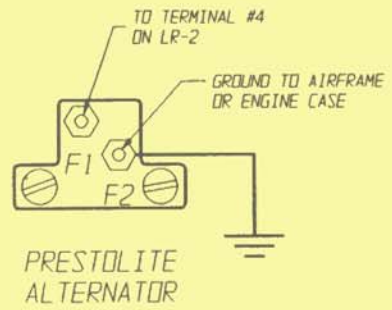

PRESTOLITE ALTERNATOR

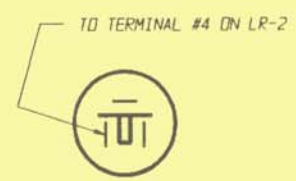

B&C L-60 ALTERNATOR

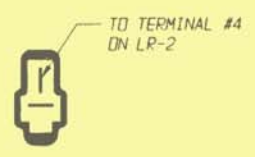

B&C L-40 ALTERNATOR

NOTE: Depending upon battery type, condition and temperature, the LOW VOLTAGE light may flash a few times and then quit when the master switch is turned on and the engine is not running. In some cases it may not flash at all. To verify low voltage sensor operation, nonentarily turn on landing lights with the alternator off-line. The LOW VOLTAGE light should begin to flash as soon as the bus voltage drops to 12 volts.

GROUND STUD: Located below terminal strip. DO NOT INSTALL A JUMPER BETWEEN #5 AND GROUND STUD. Install a separate ground wire between GROUND STUD and the main GROUND BUSS closest to the battery ground.

INSTALLATION OF LR-2 VOLTAGE REGULATOR

* Wire regulator per wiring diagram. If the regulator is being installed on a LongEze, mount it on F22, otherwise try to protect the regulator from heat, vibration, and water. Since four (4) of the seven (7) wires are between the regulator and the instrument panel, we recommend mounting it close to the instrument panel.

* There is a small piece of heat shrink tubing in the plastic bag. Cut this into four (4) pieces and install onto the wires that go to the press-to-test switch and the lamp. Finally, solder the wires onto the devices and shrink the heat shrink tubing over the connection.

* **ALWAYS** be sure that there is a wire (bonding strap) that runs between the alternator case and the engine or system ground. **DO NOT RELY ON THE ALTERNATOR MOUNTING HARDWARE FOR A GOOD GROUND!!!**

* The regulator is pre-set at 13.8V (+/- .2V). If you would like to change the output voltage of your alternator, just remove the 3/4" round plastic plug from the side of the regulator. Using a small screwdriver, turn the small screw clockwise to increase voltage, counter-clockwise to decrease the voltage (approximately 1/2 turn per .1 volts). Use a digital voltmeter connected to the battery for this measurement. Meters by B&K and Fluke are preferred, Micronta 22-185, 22-194, and 22-195 (Radio Shack) are suitable too. Micronta 22-188 and 22-171 are NOT suitable.

* The alternator field breaker should be rated at 3 AMPS.

* Install the low voltage warning light in your instrument panel. The light should be positioned within the pilots' peripheral vision (generally, a 45 degree angle in front of the pilot). It is best to install the lamp away from direct sunlight. If the lamp is in direct sunlight, be sure to test it on a sunny day to be sure that the lamp is visible while operating. The bulb is a MIDGET FLANGED #330 BULB for the 12V LR-2 or a #327 for the 24V LR-2.

* If you are on a long approach at night with low engine RPM and a heavy electrical load, the low voltage light may come on. The plastic lens can be unscrewed to turn the light off, or install a dimmer type lamp holder.

OPERATION OF THE LR-2 VOLTAGE REGULATOR

In normal operation the field breaker will be closed (ON) and the low voltage warning light will not be on (See note on the other side of the page).

LOW VOLTAGE WARNING - continuous rapid flashing of the warning light.

OVER VOLTAGE WARNING - the 3 AMP alternator field breaker will open causing alternator to be shut down. If sufficient loads are operational, the LOW VOLTAGE warning light will begin to flash in a few seconds. If electrical loads are very light, the LOW VOLTAGE light may not operate.

OVER VOLTAGE PRESS-TO-TEST SWITCH - can be depressed to test the circuitry in the OVER VOLTAGE section of the regulator. With the engine running 1000 rpm, alternator on, and other electrical loads off, momentarily depress the p.t.t. switch. The field breaker should open in 1/2 to 2 seconds. If the field breaker takes more than 2 seconds to open up, you need to change to a faster acting field breaker. **DO NOT USE THE OVER VOLTAGE PRESS-TO-TEST SWITCH MORE THAN ONE (1) TIME EVERY TEN (10) MINUTES!!!** The switch is for testing only. Using it several times in succession will overheat the LR-2.

USE THE OVER VOLTAGE PRESS-TO-TEST SWITCH ONLY IF ENGINE AND ALTERNATOR ARE RUNNING!!!